

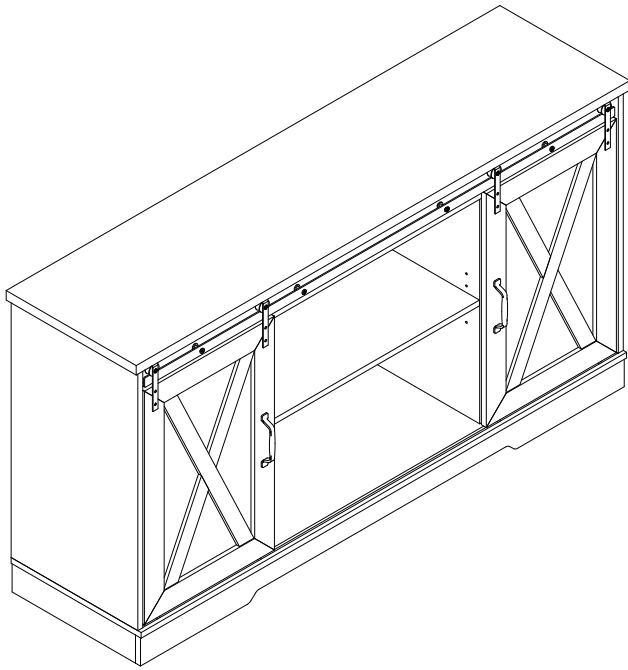











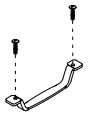

Instruction d'assemblage

à conserver pour consultation ultérieure: à lire attentivement.
Conseil de vérification de montage à faire régulièrement.
À usage domestique

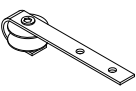

- | | | | |
|--|---|---|---|
|  |  |  |  |
| A × 22 | B × 22 | C × 27 | D × 12 |
|  |  |  |  |
| E × 26 | F × 8 | G × 2 | H × 4 |
|  |  |  |  |
| I × 6 | J × 8 | K × 4 | L × 1 |
|  |  |  | |
| M × 1 | N × 4 | O × 2 | |

1

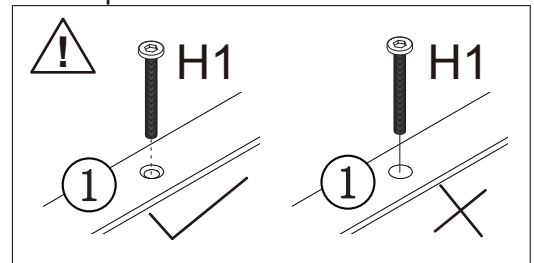
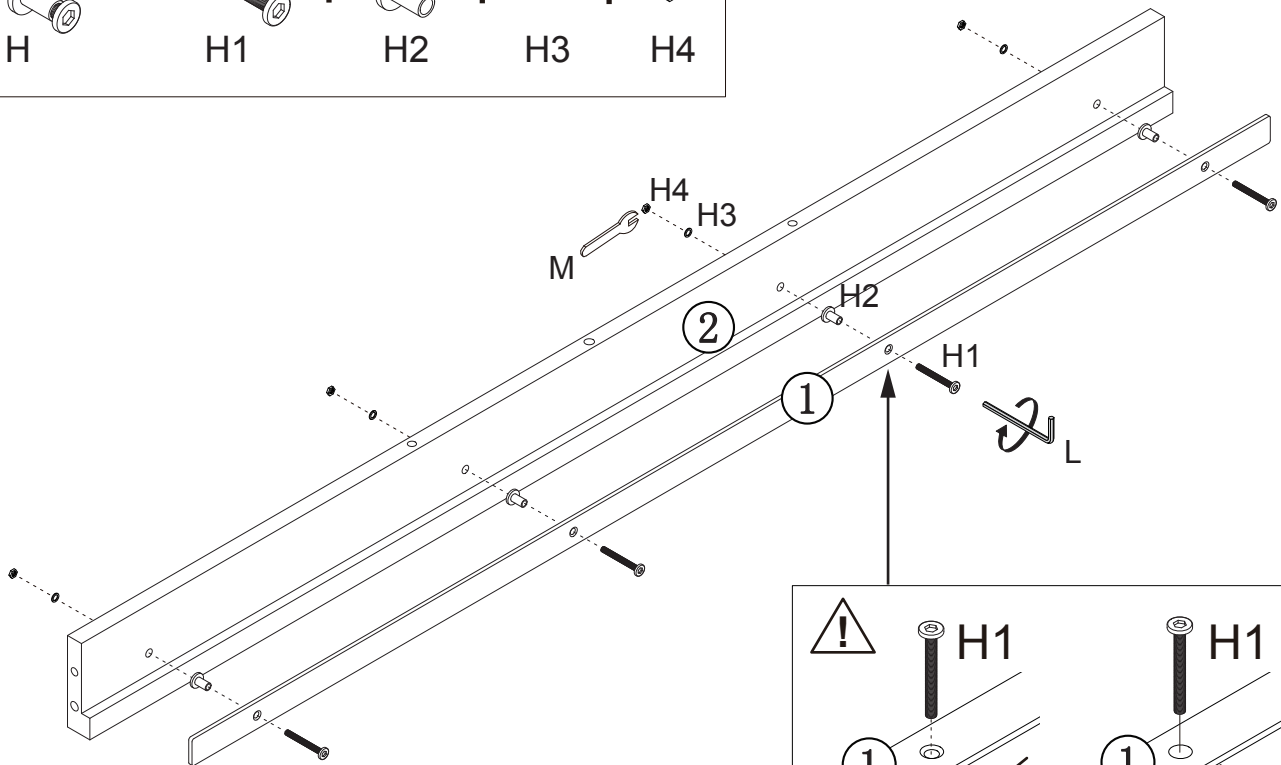
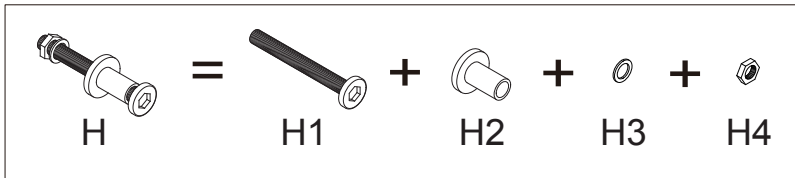

2

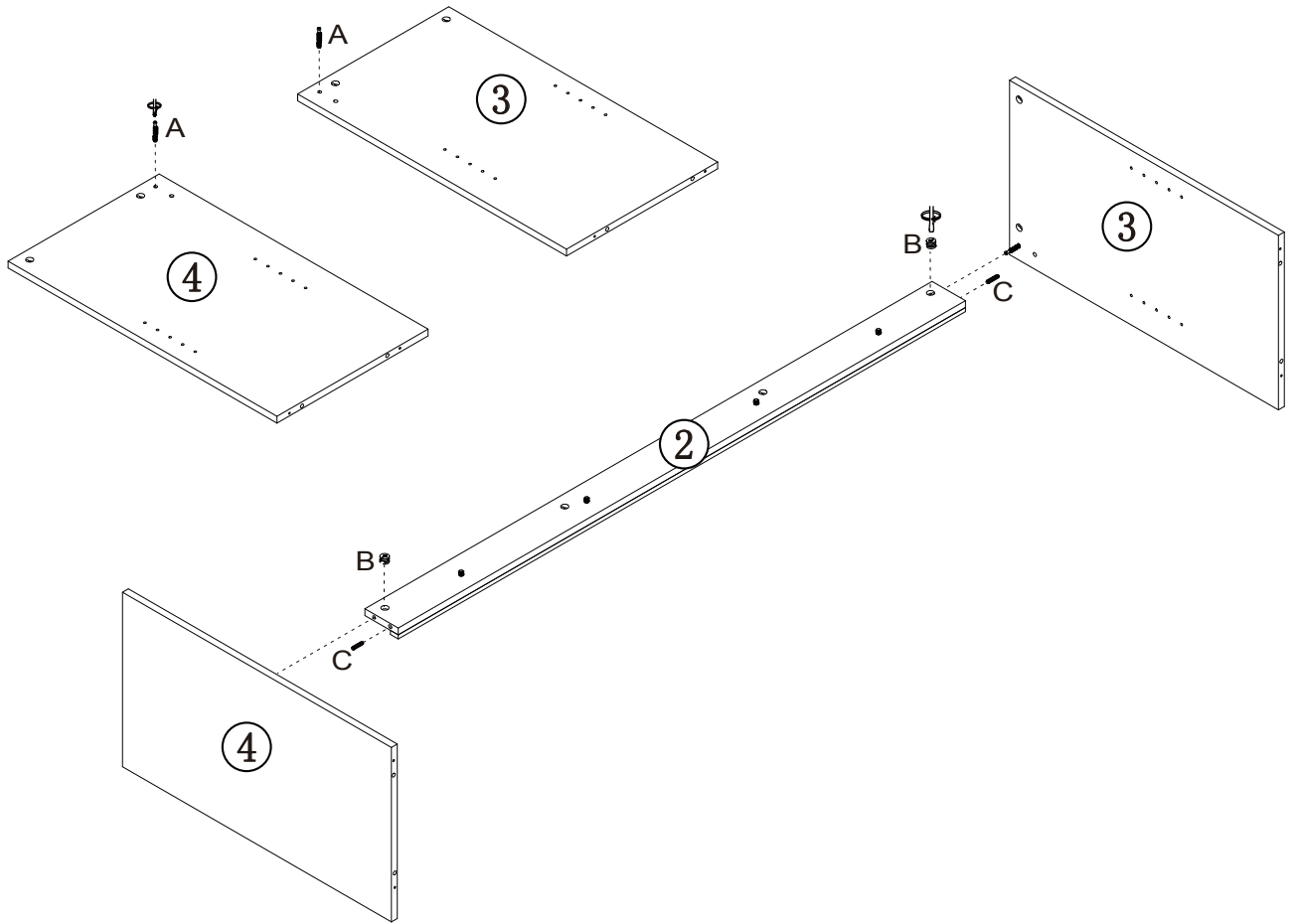

3

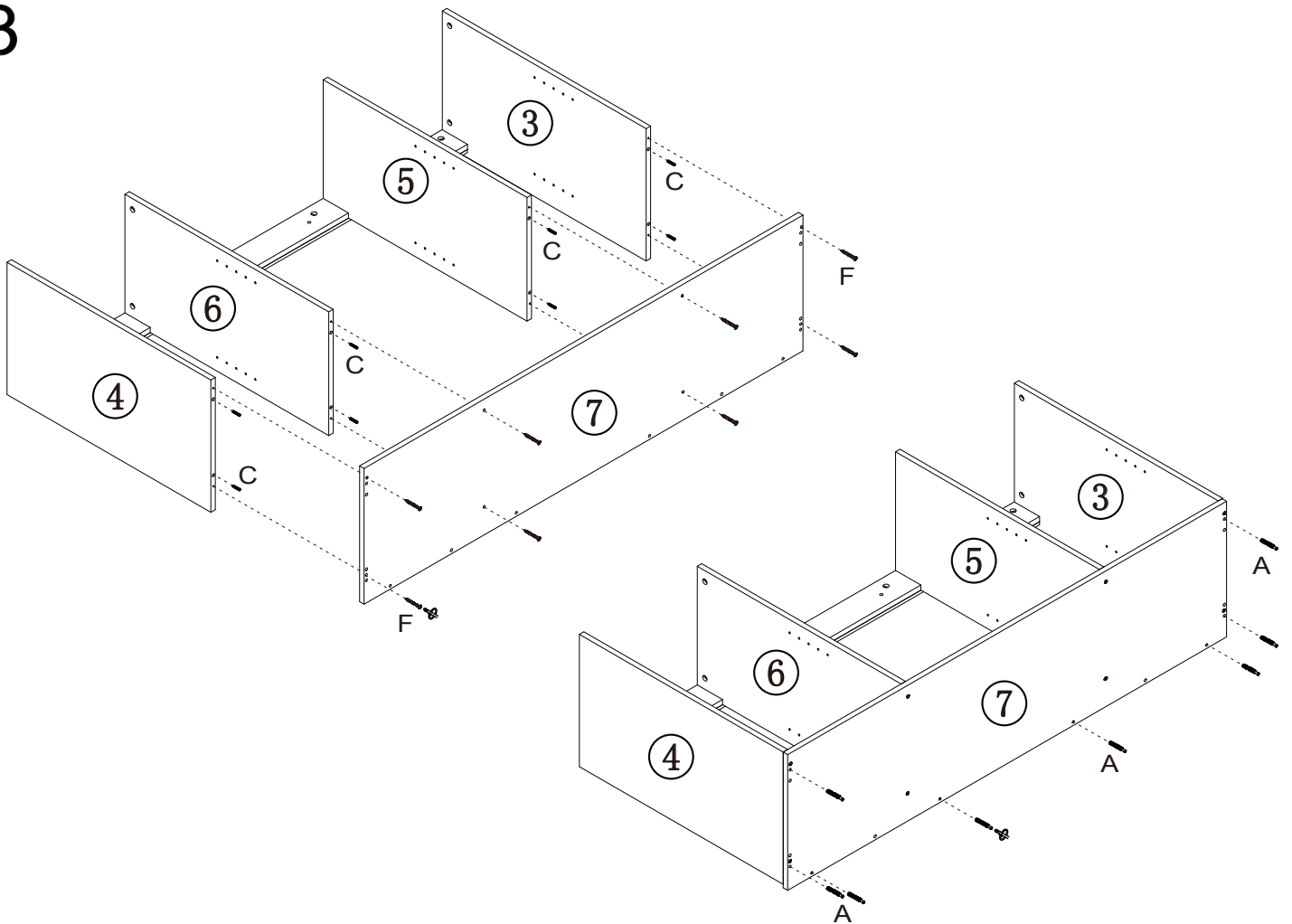

4

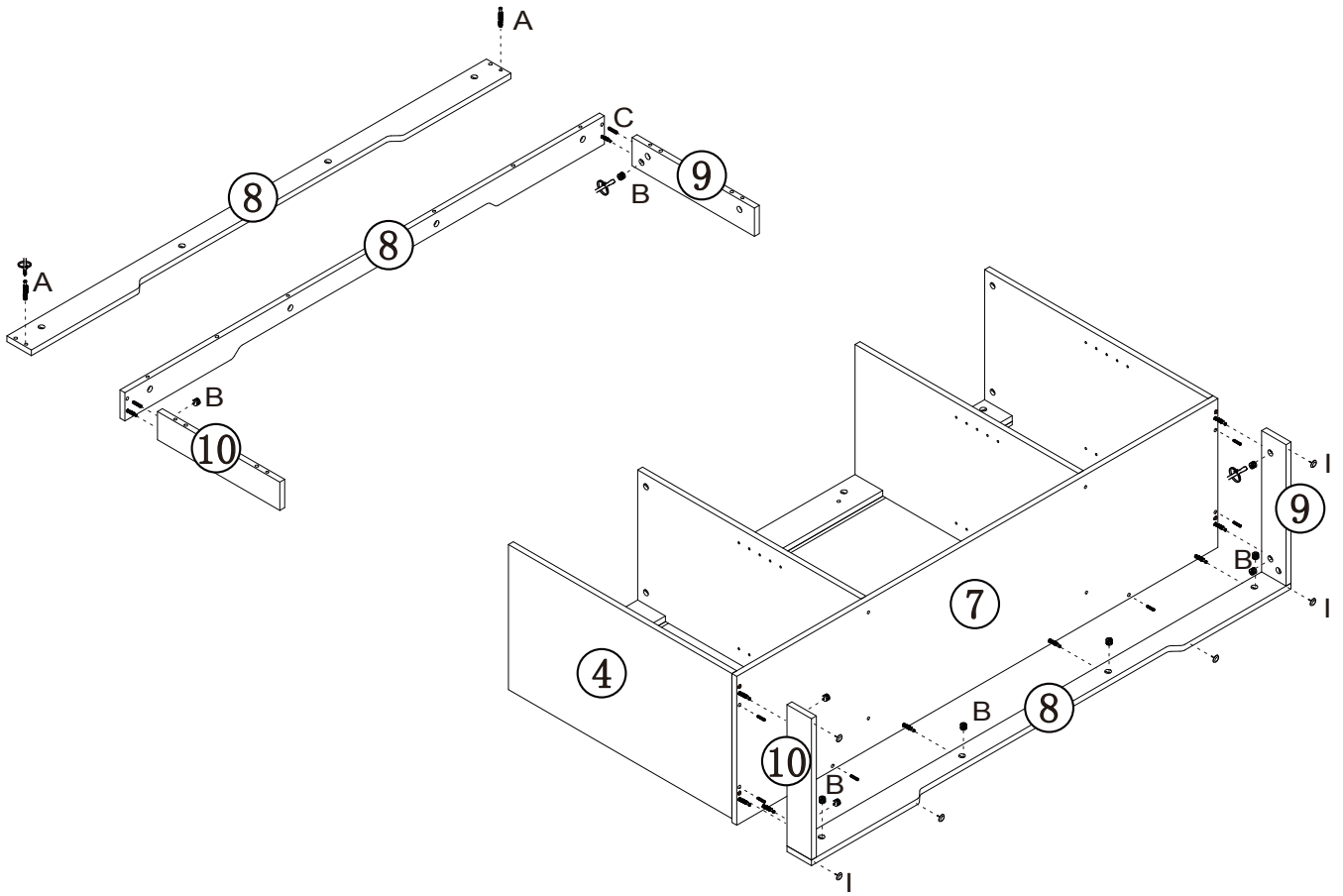

5

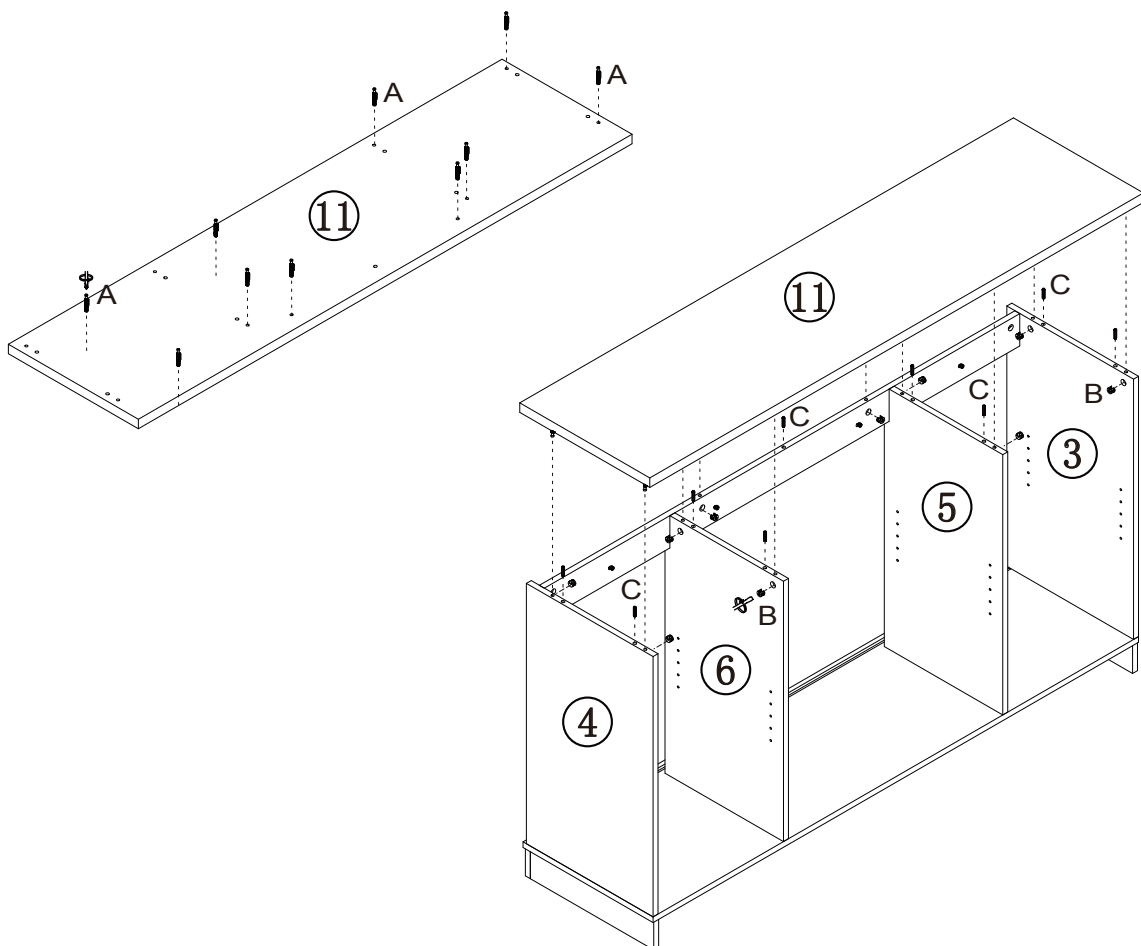

6

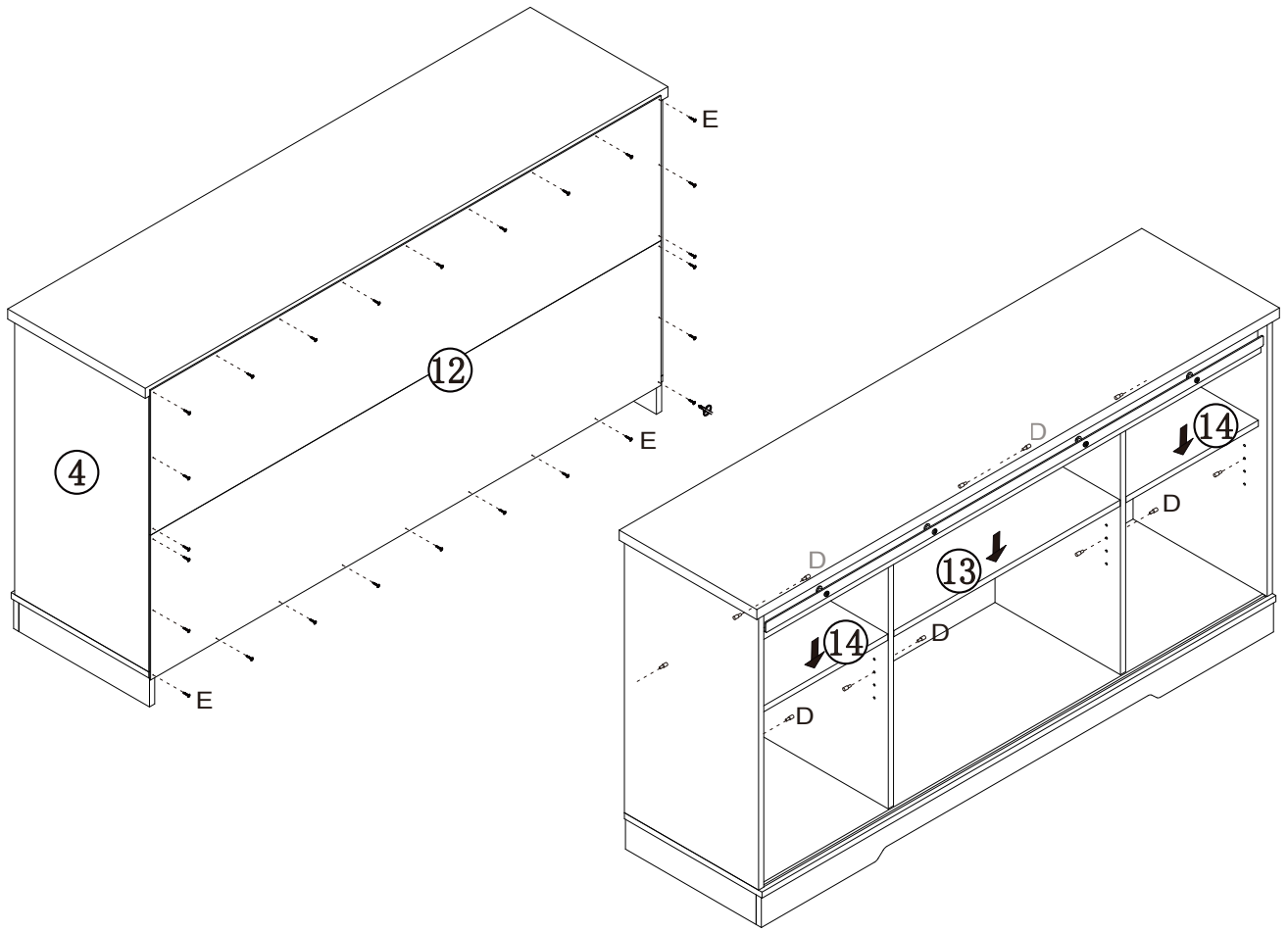

7

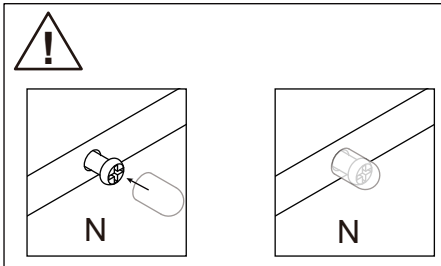
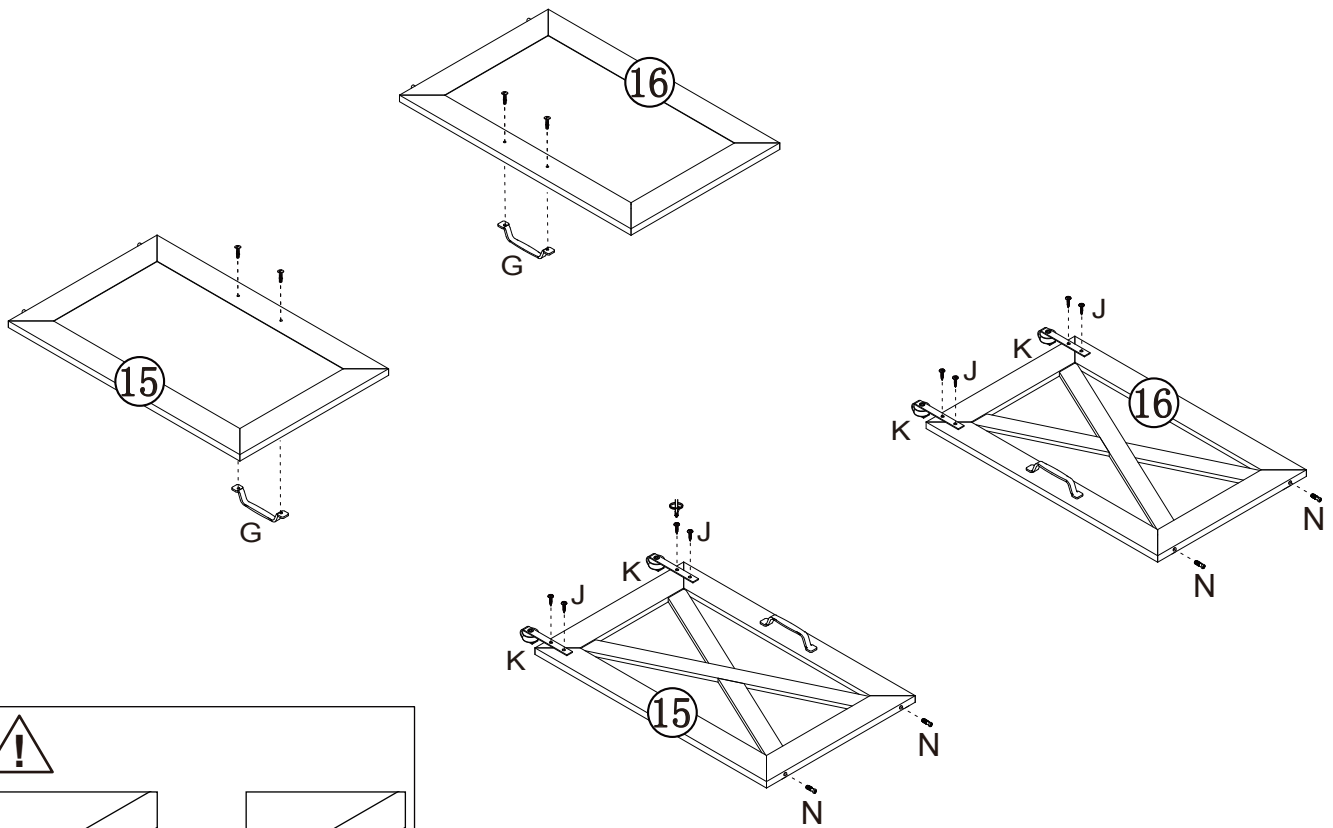

8

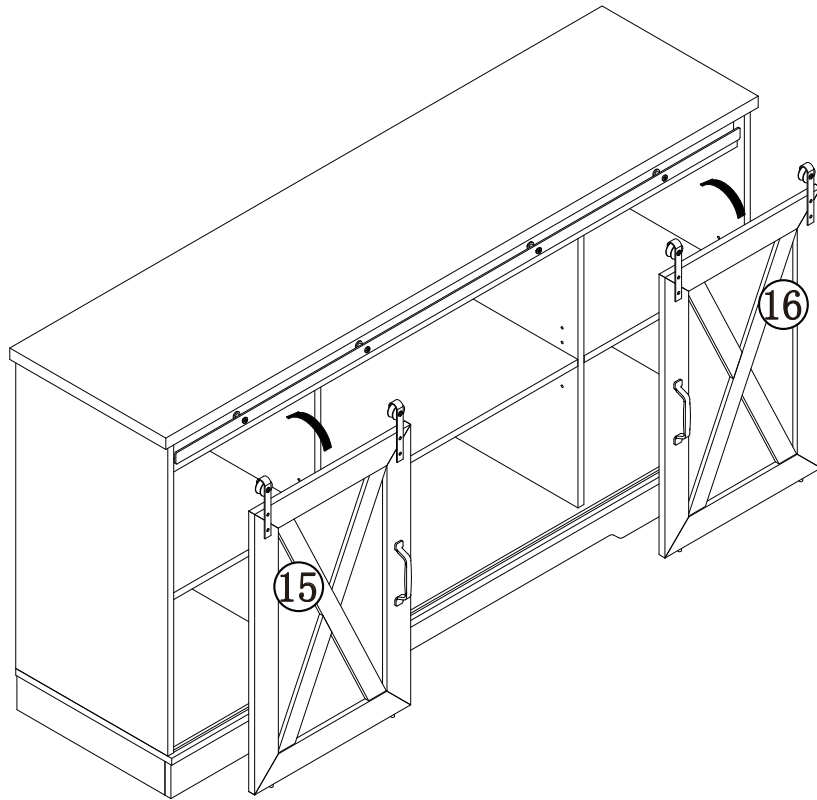

9

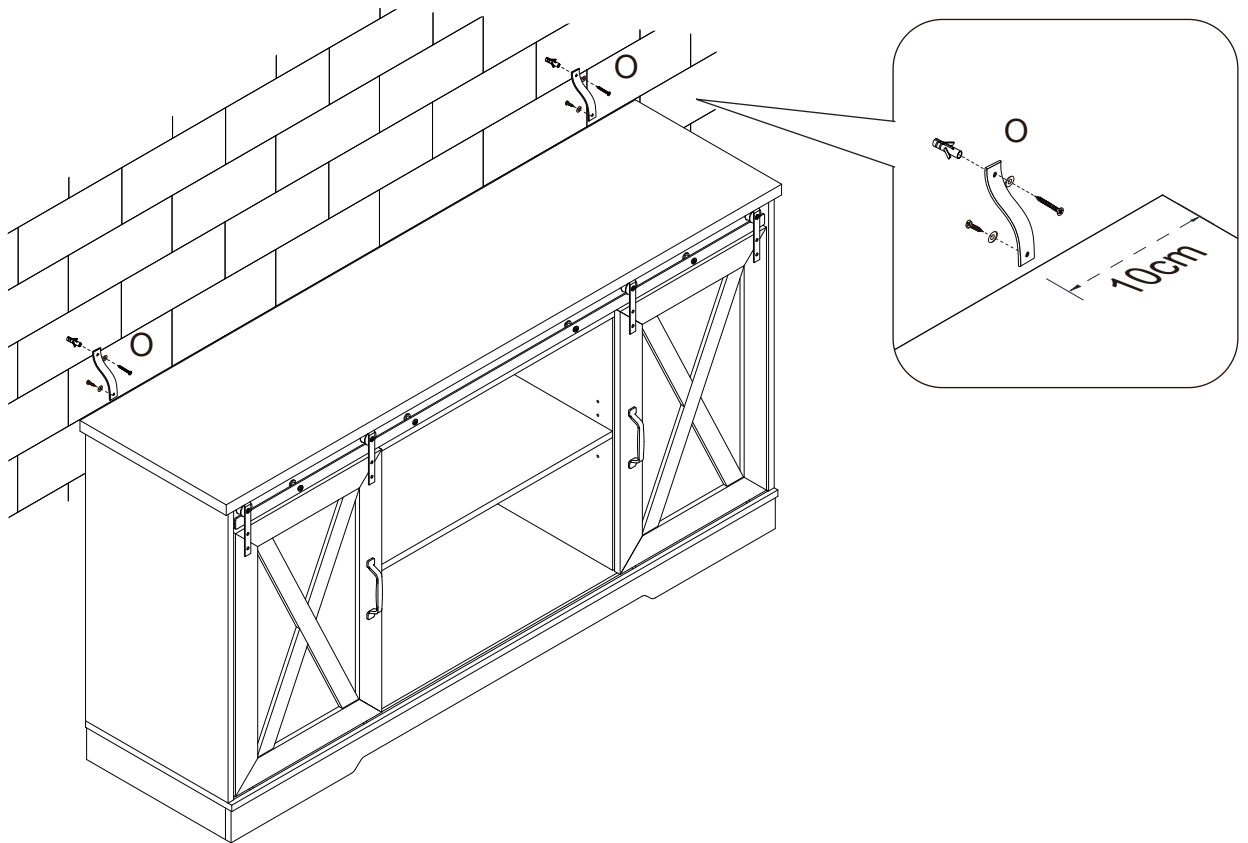

Ref#: 152015/MC50225

Description: MANHATTAN - BUFFET AVEC 2 PORTES COULISSANTES
MANHATTAN - SIDEBORD CABINET

Dimension : +/- 150x39.5x80cm



A MONTER SOI-MEME

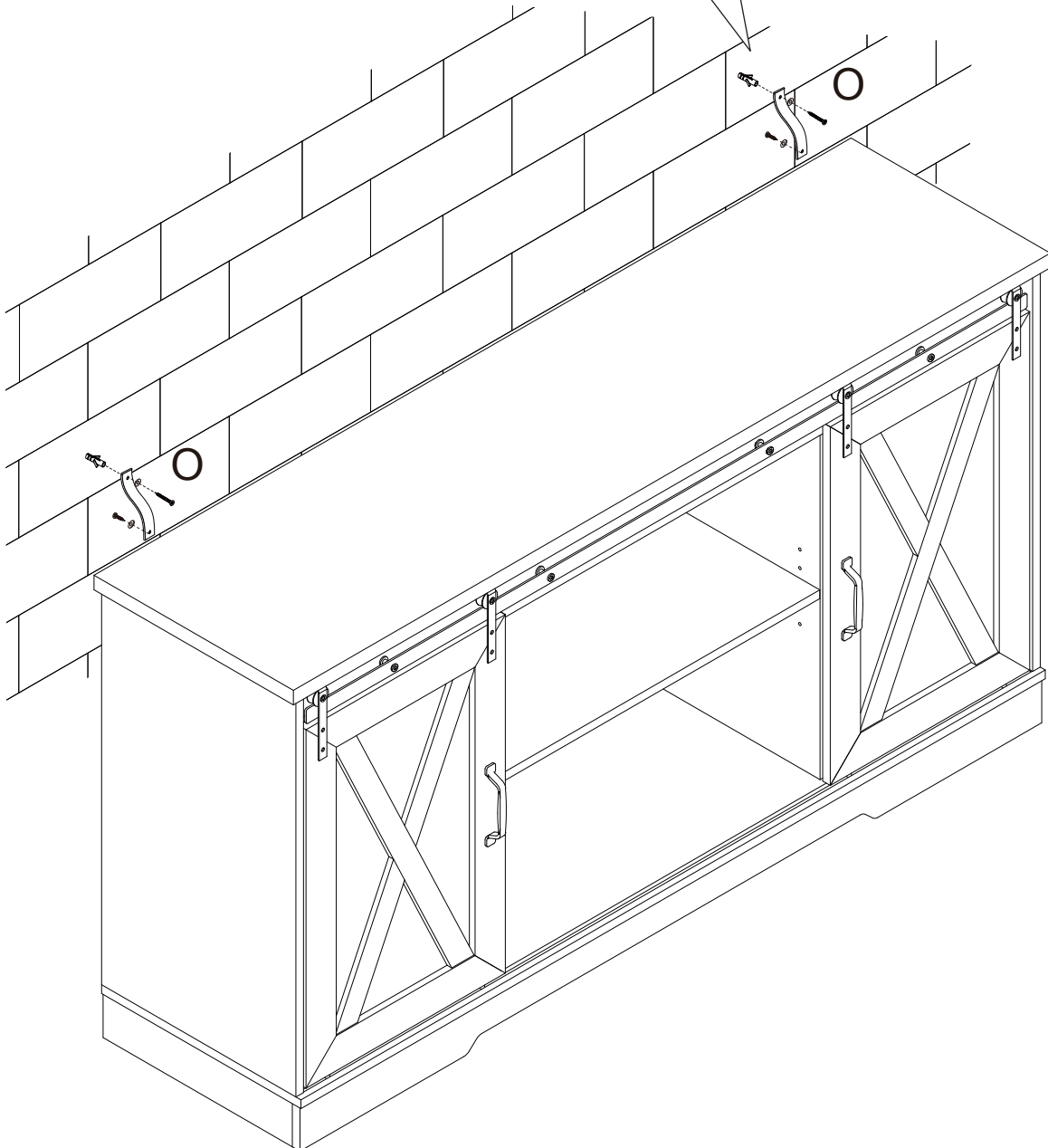
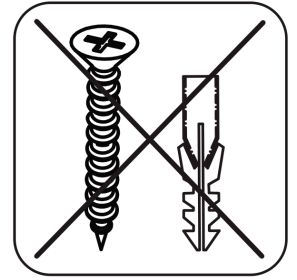
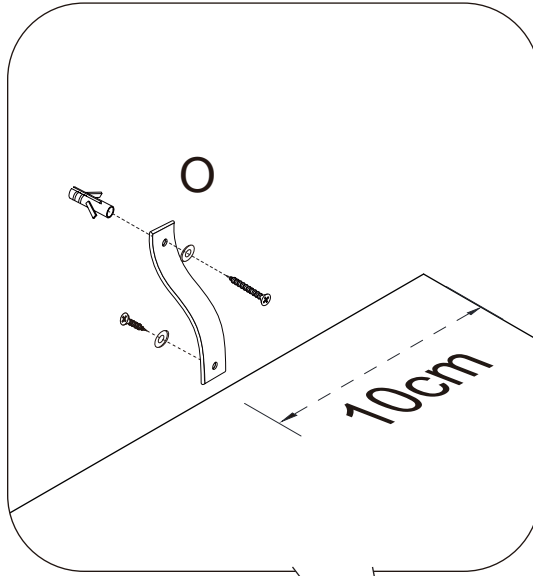



English
Important Information
Read carefully
Keep this information for further reference

WARNING

Serious or fatal crushing injuries can occur from furniture tip-over. To prevent this furniture from tipping over it must be permanently fixed to the wall with the included wall attachment devices.

Fixing devices for the wall are not included since different wall material require different type of fixing devices. Use fixing devices suitable for the walls in your home.

Français
Information importante.
A lire attentivement.
Conserver ces informations pour une utilisation ultérieure.

ATTENTION

Risque de blessure grave ou mortelle en cas de basculement du meuble. Pour éviter que le meuble ne bascule, il faut le fixer au mur de façon permanente à l'aide des pièces incluses pour la fixation.

Les vis et chevilles ne sont pas incluses car leur choix dépend du matériau du mur sur lequel est fixé le meuble. Utilisez des vis et chevilles adaptées au matériau du mur.

Nederlands
Belangrijke informatie
Goedlezen
Bewaarde deze informatie voor toekomstig gebruik

WAARSCHUWING

Wanneer meubels omvallen, kan ernstig of levensbedreigend beklemmingsletsel ontstaan. Om te voorkomen dat dit meubel omvalt, dient dit permanent met de meegeleverde wandbevestigingen aan de wand te worden bevestigd.

Bevestigingsbeslag voor de wand is niet inbegrepen, aangezien verschillende soorten bevestigingsbeslag dat geschikt is voor de wanden in je huis.

Español
Información importante
Para leer con cuidado.
Guarde esta información para su uso posterior.

ATENCIÓN

Riesgo de lesiones graves o fatales en caso de inclinación de la unidad. Para evitar que los muebles se vuelquen, deben fijarse permanentemente a la pared con las partes incluidas para su fijación.

Los tornillos y los tapones no están incluidos porque su elección depende del material de la pared en la que se fijan los muebles. Use tornillos y tacos que sean apropiados para el material de la pared.

PORTUGUÊS
Informação importante.
Para ler atentamente.
Guarde estas informações para uso posterior.

CUIDADO

Risco de ferimentos graves ou fatais em caso de inclinação da unidade. Para evitar que o móvel tombe, ele deve ser fixado permanentemente na parede com as peças incluídas para fixação.

Os parafusos e os bujões não estão incluídos porque sua escolha depende do material da parede na qual os móveis são fixos. Use parafusos e buchas adequados ao material da parede.

DEUTSCH
Wichtige Information
Sorgfältig lesen
Diese information aufbewahren.

ACHTUNG

Wenn Möbelstücke umkippen, können ernste oder lebensgefährliche Verletzungen durch Einklemmen die Folge sein. Um zu verhindern, dass dieses Möbelstück umkippt, muss es mit dem beigepackten Vorrichtung zur Wandbefestigung fest an der Wand verankert werden.

Beschläge für die Wandbefestigung sind nicht beigepackt, da sie von der Beschaffenheit der Wand und des Untergrundmaterials abhängig sind. Befestigungsbeschläge benutzen, die für die heimischen Wände geeignet sind.